

Cryptocurrency-Based Financial Science Strategy in World Influence Using Causal Diagram and Machine Learning

Gilang Pratama

Master of Management Science, Faculty of Economic and business, Universitas Padjajaran, Indonesia

Abstract

Cryptocurrency is a digital currency that can be used for transaction on an international scale and as an investment. The potential provided by cryptocurrency in the development of the digital economy in the world has become a special attraction for individuals, organizations, and government. Blockchain system that underlies cryptocurrencies has worked flawlessly in both the financial and non-financial worlds. This study uses Basic Risk Management Ishikawa Diagram and evaluated by ARIMA predictive algorithm in determining cause and effect of the development of cryptocurrencies. It was found that the development of cryptocurrency is very influential by the state of the world, especially countries that have great influence such as USA. USA inflation have a big influence, and the model can be used as a basis for a country's government in observing.

Keywords: cryptocurrency; digital economy; ishikawa diagram; ARIMA; machine learning; rapid miner.

Received: 5 October 2023

Revised: 14 December 2023

Accepted: 21 December 2023

1. Introduction

Blockchain is a collection of digital data or a data bank consisting of economic transactions or objects that have value and cannot be altered by time, but are managed by a group of machines that do not belong to an individual or group (Crosby et al., 2016). Transactions that occur within the Blockchain system cannot be deleted because all transactions will leave a certain record and every history that occurs can be verified. Cryptocurrency or digital currency, which has become increasingly popular in the global economy, has attracted various groups ranging from investors, academics, to policy makers or governments. The development of cryptocurrency itself began to be seen in 2017, which made the cryptocurrency market a source of criticism and heated debate. According to Joseph Stiglitz and Robert Shiller, "Bitcoin ought to be outlawed" while the latter highlighted that investor interest in the cryptocurrency market was due to its anti-government, anti-regulation fee. From an academic perspective, there is a big debate as to whether cryptocurrency is a currency or an asset (Liu & Serletis, 2019). Historical data from www.tradingview.com Bitcoin opened in February 2017 at USD\$1000, reached USD\$20,000 in December 2017, then experienced a decline in February 2018 to USD\$8000, and underwent rapid increases and decreases in 2019, which caused the average price of Bitcoin to reach USD\$7000. During the COVID-19 pandemic, there was a significant increase in the price of Bitcoin, reaching USD\$24,000 in December 2020.

In the world, there are four prominent digital currencies in terms of market value and have been widely used in international transactions, namely Bitcoin (BTC), Ethereum (ETH), Bitcoin Cash (BCH), and Litecoin (LTC). Bitcoin or BTC was introduced by Satoshi Nakamoto as the first pioneer to introduce the concept of peer-to-peer E-Money and described the network and exchange media using cryptography as security where transactions are done directly through a centralized system. The emergence of Ethereum or ETH was pioneered by Vitalik Buterin in 2013 who proposed a new and more functional blockchain implementation that now has smart contract features to ensure integrity in each blockchain node. Bitcoin Cash or BCH is a derivative asset of BTC due to the lack of consensus within the BTC community. Litecoin or LTC is a cryptocurrency released under MIT/X11 license, developed by Charlie Lee, and is often referred to as silver, with BTC being gold since the majority of LTC uses the same basis as BTC. "The use of cryptocurrency in international transactions will eliminate differences in interest rates and foreign exchange rates" (Fang

* Corresponding author.

E-mail address: gilang21006@mail.unpad.ac.id

et al., 2022). “Simpler infrastructure and cheaper cryptocurrency transaction costs are an advantage and benefit compared to the international money market” (Enajero, 2021). “Cryptocurrency acts as a loss limit” (Wang et al., 2021). “Bitcoin and cryptocurrency have special features that complement the currency in developing countries. In addition, the risks to the cryptocurrency system can be minimized, while at the same time having an important role in the development of the economy in developing countries” (Zhao, 2021). The complementary nature, especially towards the currency in developing countries, is related to the equalization of the value of currency internationally. “Cryptocurrency has the potential to accelerate the development of e-commerce in a country” (Erdogan et al., 2022). “Blockchain technology in Bitcoin has the potential to create a new value system that supports social dynamics. As in the perspective of technology and economics” (Bartolucci et al., 2020). The analysis is based on the fact that besides functioning as a long-term investment, cryptocurrency can be widely accepted as a means of exchange.

Indeed, the rapid development of technology, including Artificial Intelligence (AI) and Machine Learning (ML), has contributed to various sectors such as industry, agriculture, healthcare, and even education (Han et al., 2012; North, 2012). While AI and ML have provided many benefits, they are also responsible for some negative effects, such as privacy violations (Russell, 2018), fear of job replacement with robots (Zhang, 2017), and a decrease in well-being (Telonis & Groumpos, 2017). In general, the development of technology can be directed towards positive outcomes depending on how it is designed from the outset, including what can and cannot be done. In the context of AI and ML, instead of being developed as a replacement for human beings, they should be created to “serve the needs” rather than be a complete substitute. In the financial context, AI and ML are defined as predictions made on financial data that are time-series in nature (Aggarwal, 2015; Ye, 2013). Moreover, the application of AI and ML, especially in the form of applications, provides ease in making decisions (Laursen & Thorlund, 2017; Olson, 2007).

The Fishbone Diagram (Ishikawa Diagram) is one of the basic risk management tools for analyzing a process to be analyzed. The Ishikawa Diagram was developed by Kaoru Ishikawa, and this diagram depicts the main causes and sub-causes of a process or impact that arises (cause-effect diagram) (Ishikawa, 1989). Cause and Effect Diagram, or Fishbone Diagram, is a method for identifying, sorting, and displaying the causal factors of a problem. This diagram depicts the relationship between the problem and all categories of causes that affect the problem (Hason Rudd et al., 2022).

ARIMA is one of the ML algorithms, which is basically a combination of the Autoregressive (AR) and Moving Average (MA) models. The AR model is a linear equation of past variable values to predict future values. The autoregression method (AR) is essentially a regression model applied to lag, where the lag becomes a new predictor of the dependent variable (Dietrich et al., 2015; Kotu & Deshpande, 2015). In this study, the value of cryptocurrency will be compared to DXY, Euro, and US CPI to determine the extent of the influence of currencies on digital currencies, particularly Bitcoin. The Consumer Price Index (CPI) is an index used to calculate the cost of living in a country (Johnson, 1999). CPI is usually calculated to assess the success of inflation targeting. The U.S. Dollar Index (DXY) is an index that reflects and measures the strength of the US Dollar against six other major world currencies (Euro, Japanese Yen, British Pound, Canadian Dollar, Swedish Krona, and Swiss Franc) (ICE Futures U.S., n.d.).

From this research, the author hopes that by identifying the causes of the emergence of digital currencies, it can convince individuals and governments to recognize the existence of digital currencies and authorize the use of global payments with digital currencies. With the increasing trend of E-Commerce worldwide, payment using digital currencies can simplify transactions on an international scale and eliminate the differences in currency values across the world. Additionally, this research also evaluates the performance of ML on time-series data. All tables should be numbered with Arabic numerals. Headings should be placed above tables, left justified. Only horizontal lines should be used within a table, to distinguish the column headings from the body of the table, and immediately above and below the table. Tables must be embedded into the text and not supplied separately. Below is an example which authors may find useful.

2. Literature Review

The study conducted (Karabağ & Fadıloğlu, 2021) comparing the performance of forecasting algorithms on beer sales was motivated by the presence of asynchronous seasonalities in the sales data. The study employed the Augmented Winter, TBAT, ETS, and ARIMA algorithms to forecast beer sales from January 2008 to December 2013. It was found that the Augmented Winter algorithm performed better in forecasting under asynchronous seasonality.

In the study “Bank transaction data modeling by optimized hybrid machine learning merged with ARIMA” (Kullaya Swamy & Sarojamma, 2020), the researchers aimed to design an efficient model for predicting bank transactions

based on previous transactions, as traditional statistical features were found to be less efficient. The study applied Deep Belief Network (DBN), Neural Network (NN), Lion Algorithm, Artificial Bee Colony Algorithm, and ARIMA model to 128 months of transaction history at a bank. The study found that for optimal results in modeling transaction data, DBN and NN models were used to produce the prediction output, aided by the hybrid L-ABC algorithm in minimizing errors. The study found that the L-ABC algorithm yielded better results.

3. Research Method and Materials

In this study, the basic risk management methodology (Ishikawa Diagram) was used to identify the causes and development of cryptocurrencies, and the CRISP-DM data mining process was applied. “Extracting useful knowledge from data to solve business problems can be treated systematically by following a process with reasonably well-defined stages” (Chapman et al., 2000; Provost & Fawcett, 2013; Sharda et al., 2014). The time-series data used in this study consisted of 1,827 data points (from October 13, 2017, to October 13, 2022) obtained from <http://finance.yahoo.com/> which includes open, close, and date reports on Bitcoin, DXY, and EURO/USD, and historical data on CPI US obtained from <https://www.tradingeconomics.com/>. The cryptocurrency analysis will be performed using the Ishikawa Diagram, and the results will be evaluated and applied to forecasting using the ARIMA algorithm in RapidMiner with the CRISP-DM methodology to obtain accurate findings.

3.1. Basic Risk Management

The analysis of cryptocurrency development using the Ishikawa Diagram focused on five main categories: environment, power, method, people, and measurement (Figure 1). It was found that cryptocurrency has a strong power that supports its existence as a digital currency in the world, allowing it to be utilized for its advantages as an official and legitimate digital currency for payments. The value of cryptocurrency was also found to have a measurement value that is almost the same as conventional currencies, where the values of crypto have a significant impact on the world situation (Ftiti et al., 2021). The development of cryptocurrency greatly influences the people involved in it (Pavlou & Gefen, 2004). The advantages of crypto, such as its peer-to-peer system without intermediaries and its decentralized system, are utilized by individuals with personal interests for their own gain. This is done to take advantage of the strengths and weaknesses of cryptocurrency, so now supervision of trading platforms needs to be increased by conducting monitoring of proof-of-reserve to ensure that the amount of currency held by individuals or groups has a sample value.

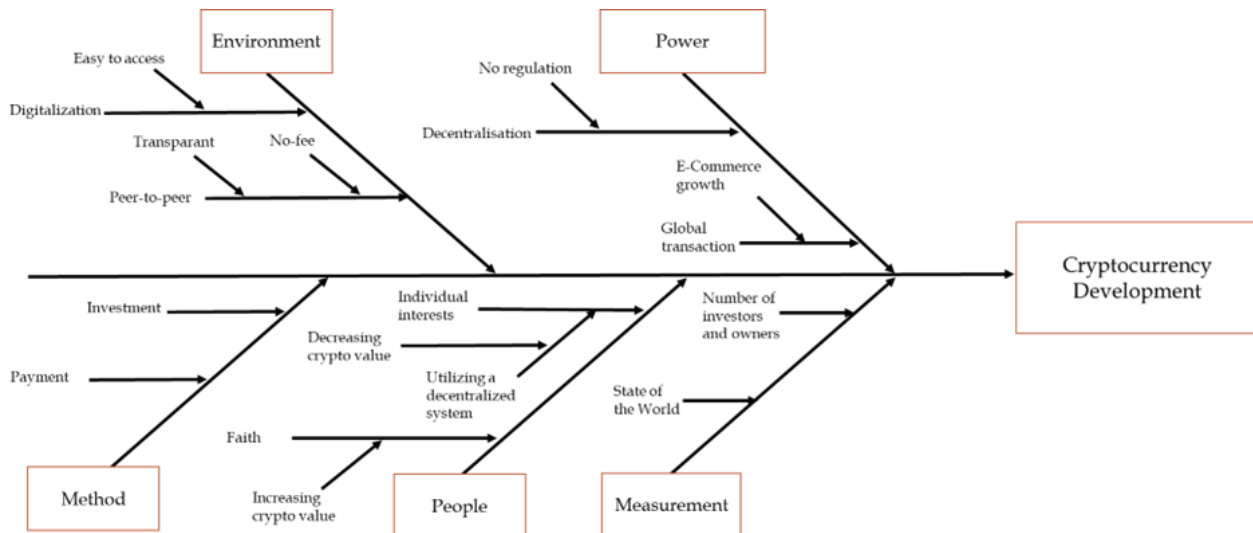

Figure 1. Ishikawa Diagram

3.2. CRISP-DM

3.2.1. Business Understanding

The comprehensive analysis was conducted on Bitcoin's attributes, encompassing key factors such as DXY (US Dollar Index), EUR/USD exchange rate, and CPI US (Consumer Price Index in the United States), in order to meticulously

evaluate and quantify the impact of each of these attributes on the fluctuation and valuation of Bitcoin, and meticulously conducted to gain a deep understanding of Bitcoin's behavior and its interplay with critical economic variables. The objective was not only to determine the influence of these factors on Bitcoin's valuation but also to harness these insights for government decision-making and policy formulation. The findings of this analysis hold significant implications for government bodies, central banks, and regulatory authorities. By quantifying the impact of these attributes on Bitcoin's value, policymakers can make informed decisions regarding cryptocurrency regulation, taxation, and monetary policy. Furthermore, the Bitcoin value forecasting component of this analysis equips governments with essential foresight, allowing them to proactively respond to potential economic shifts, market volatility, and emerging trends within the cryptocurrency ecosystem. Additionally, this analysis delved into the realm of Bitcoin value forecasting, aiming to provide valuable insights into the future trajectory of Bitcoin's worth, thereby equipping stakeholders with the strategic knowledge required for informed decision-making in the dynamic cryptocurrency market. Ultimately, the results of this analysis serve as a valuable tool in guiding government actions and policies related to the cryptocurrency sector, ensuring financial stability, consumer protection, and regulatory compliance in a rapidly evolving digital financial landscape

3.2.2. *Data Understanding*

The data used in this study is a time-series data consisting of 1,827 observations and includes 48 attributes, as shown in (Figure 2), i.e.;

- | | | |
|-------------------|---|---------------------------------------|
| a) BTC | = | Value Bitcoin |
| b) Date | = | BTC data collection date |
| c) DXY | = | U.S. Dollar Index |
| d) Date2 | = | DXY data collection date |
| e) EUR-USD | = | Euro trading value against the Dollar |
| f) Date3 | = | EUR-USD data collection date |
| g) Inflation Rate | = | US inflation rate |
| h) Date4 | = | US inflation rate collection date |

In this analysis, BTC is used as the label to measure the influence of three compared attributes (DXY, EUR-USD, and Inflation Rate) on BTC. The goal is to identify the relationship between BTC and these three attributes, as well as to forecast the value of BTC based on the historical data. After combining the four time-series data, the dataset was preprocessed by removing any missing values and normalizing the attributes to have zero mean and unit variance. The correlation between the attributes was then calculated.

Based on observations of the data, it was found that the date attribute or the data collection attribute is not consistently the same, with differences in dates occurring. Additionally, there are missing values in the collected data (Figure 2).

3.2.3. *Data Preparation*

In this step, three operators were applied to correct the data that had inconsistent data collection dates and to remove missing values (Figure 2) so that the data can be used for the next step (Figure 3) and meet the necessary requirements (Figure 4). The following are the explanations of the operators used:

- 1) The Equalize Time Stamps operator is used to create or standardize data according to the specified date or time stamps (RapidMiner GmbH, 2019). In this context, the time stamp applied was 1.827 days, corresponding to the amount of BTC USD data. The “previous value” approach was used to fill in the missing time stamps;
- 2) Merge Attribute operator is used to merge two or more obtained datasets (RapidMiner GmbH, 2019). In this context, four datasets were merged: BTC-USD, DXY, EUR-USD, and Inflation Rate, in order to create one dataset (Figure 2); and;
- 3) Select Attribute. Select Attribute operator is used to select the necessary attributes from the existing dataset (RapidMiner GmbH, 2019). In this context, five attributes were selected, namely: date, BTC, DXY, EUR-USD, and Inflation Rate.

Row No.	BTC	Date	Date2	DXY	Date3	EUR-USD	Date4	Inflation Rate
1	5.647	Oct 13, 2017	Oct 13, 2017	93.090	Oct 13, 2017	1.183	Oct 13, 2017	2.041
2	5.832	Oct 14, 2017	Oct 15, 2017	?	Oct 16, 2017	1.181	Nov 13, 2017	2.203
3	5.678	Oct 15, 2017	Oct 16, 2017	93.280	Oct 17, 2017	1.179	Dec 13, 2017	2.109
4	5.726	Oct 16, 2017	Oct 17, 2017	93.490	Oct 18, 2017	1.177	Jan 13, 2018	2.071
5	5.606	Oct 17, 2017	Oct 18, 2017	93.360	Oct 19, 2017	1.180	Feb 13, 2018	2.212
6	5.591	Oct 18, 2017	Oct 19, 2017	93.270	Oct 20, 2017	1.185	Mar 13, 2018	2.360
7	5.709	Oct 19, 2017	Oct 20, 2017	93.700	Oct 23, 2017	1.175	Apr 13, 2018	2.463
8	6.011	Oct 20, 2017	Oct 22, 2017	?	Oct 24, 2017	1.176	May 13, 2018	2.801
9	6.032	Oct 21, 2017	Oct 23, 2017	93.940	Oct 25, 2017	1.176	Jun 13, 2018	2.872
10	6.008	Oct 22, 2017	Oct 24, 2017	93.960	Oct 26, 2017	1.182	Jul 13, 2018	2.950
11	5.930	Oct 23, 2017	Oct 25, 2017	93.710	Oct 27, 2017	1.164	Aug 13, 2018	2.699
12	5.527	Oct 24, 2017	Oct 26, 2017	94.610	Oct 30, 2017	1.160	Sep 13, 2018	2.277
13	5.751	Oct 25, 2017	Oct 27, 2017	94.920	Oct 31, 2017	1.165	Oct 13, 2018	2.522
14	5.905	Oct 26, 2017	Oct 29, 2017	?	Nov 1, 2017	1.165	Nov 13, 2018	2.177
15	5.781	Oct 27, 2017	Oct 30, 2017	94.490	Nov 2, 2017	1.163	Dec 13, 2018	1.910
16	5.753	Oct 28, 2017	Oct 31, 2017	94.550	Nov 3, 2017	1.166	Jan 13, 2019	1.551
17	6.154	Oct 29, 2017	Nov 1, 2017	94.820	Nov 6, 2017	1.161	Feb 13, 2019	1.520
18	6.131	Oct 30, 2017	Nov 2, 2017	94.690	Nov 7, 2017	1.161	Mar 13, 2019	1.863
19	6.468	Oct 31, 2017	Nov 3, 2017	94.940	Nov 8, 2017	1.160	Apr 13, 2019	1.996
20	6.767	Nov 1, 2017	Nov 5, 2017	?	Nov 9, 2017	1.160	May 13, 2019	1.790
21	7.079	Nov 2, 2017	Nov 6, 2017	94.720	Nov 10, 2017	1.165	Jun 13, 2019	1.648
22	7.208	Nov 3, 2017	Nov 7, 2017	94.910	Nov 13, 2017	1.166	Jul 13, 2019	1.811
23	7.380	Nov 4, 2017	Nov 8, 2017	94.870	Nov 14, 2017	1.166	Aug 13, 2019	1.750
24	7.407	Nov 5, 2017	Nov 9, 2017	94.440	Nov 15, 2017	1.179	Sep 13, 2019	1.711
25	7.023	Nov 6, 2017	Nov 10, 2017	94.390	Nov 16, 2017	?	Oct 13, 2019	1.764
26	7.144	Nov 7, 2017	Nov 12, 2017	?	Nov 17, 2017	1.178	Nov 13, 2019	2.051

ExampleSet (1,827 examples, 1 special attribute, 7 regular attributes)

Figure 2. Result of four time-series data

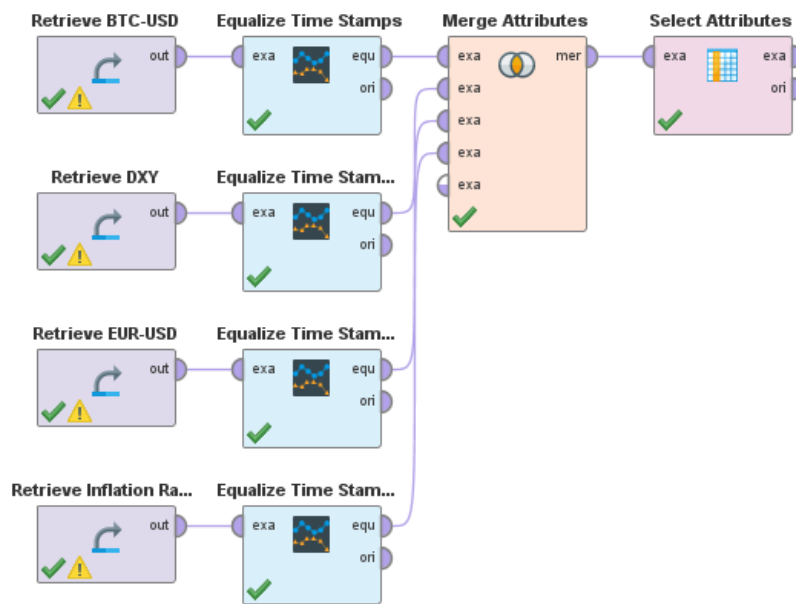

Figure 1. Operator

Row No.	BTC	Date	DXY	EUR-USD	Inflation Rate
1	5.647	Oct 13, 2017 ...	93.090	1.183	2.041
2	18.728	Oct 14, 2022 ...	113.320	0.975	8.202
3	18.728	Oct 15, 2027 ...	113.320	0.975	8.202
4	18.728	Oct 15, 2032 ...	113.320	0.975	8.202
5	18.728	Oct 16, 2037 ...	113.320	0.975	8.202
6	18.728	Oct 17, 2042 ...	113.320	0.975	8.202
7	18.728	Oct 18, 2047 ...	113.320	0.975	8.202
8	18.728	Oct 18, 2052 ...	113.320	0.975	8.202
9	18.728	Oct 19, 2057 ...	113.320	0.975	8.202
10	18.728	Oct 20, 2062 ...	113.320	0.975	8.202
11	18.728	Oct 21, 2067 ...	113.320	0.975	8.202
12	18.728	Oct 21, 2072 ...	113.320	0.975	8.202
13	18.728	Oct 22, 2077 ...	113.320	0.975	8.202
14	18.728	Oct 23, 2082 ...	113.320	0.975	8.202
15	18.728	Oct 24, 2087 ...	113.320	0.975	8.202
16	18.728	Oct 24, 2092 ...	113.320	0.975	8.202
17	18.728	Oct 25, 2097 ...	113.320	0.975	8.202
18	18.728	Oct 27, 2102 ...	113.320	0.975	8.202
19	18.728	Oct 28, 2107 ...	113.320	0.975	8.202
20	18.728	Oct 28, 2112 ...	113.320	0.975	8.202
21	18.728	Oct 29, 2117 ...	113.320	0.975	8.202
22	18.728	Oct 30, 2122 ...	113.320	0.975	8.202
23	18.728	Oct 31, 2127 ...	113.320	0.975	8.202
24	18.728	Oct 31, 2132 ...	113.320	0.975	8.202
25	18.728	Nov 1, 2137 1...	113.320	0.975	8.202
26	18.728	Nov 2, 2142 1...	113.320	0.975	8.202

ExampleSet (1,827 examples, 1 special attribute, 4 regular attributes)

Figure 2. Result of data preparation

The ARIMA modelling algorithm (Figure 5) uses the necessary operators to obtain the prediction results. The following are the operators used: 1) Multiply operator is used to multiply the output generated by the previous operator with a certain scaling factor, such as multiplying the output by the number of input data to generate prediction results that match the desired number of data. (RapidMiner GmbH, 2019); 2) Weight by Correlation operator calculates the correlation coefficient between the selected attributes and the label to determine the strength of the relationship between them. The resulting correlation values range from -1 to 1, with values closer to 1 indicating a strong positive correlation, values closer to -1 indicating a strong negative correlation, and values close to 0 indicating a weak or no correlation. (RapidMiner GmbH, 2019); 3) The ARIMA operator has several parameters to configure the modeling process. The time series attribute parameter determines the attribute where the ARIMA model is built, and the user can enter the attribute name in this parameter. The “has indices” parameter indicates whether there is an index attribute associated with the time series. If the “has indices” parameter is selected, the “indices attribute” parameter must be filled with the corresponding index, such as the date or time attribute. The “p” parameter is the number of lags to be used in the autoregressive model. The “d” parameter defines how often the time series values are differentiated. Finally, the “q” parameter is the order for the moving-average model. (RapidMiner GmbH, 2019); 3) Apply Forecast operator used to apply the ARIMA model to predict values in a specified timezone. This operator takes the ARIMA model generated by the previous operators as input, and applies it to a new dataset to generate predictions. The input dataset should have the same attributes and structure as the original training data, except for the time period to be predicted. The operator can be configured to predict values for a specific timezone by adjusting the input parameters to match the desired

timezone. The output of the “Apply Forecast” operator is a dataset that contains the predicted values for the specified timezone. (RapidMiner GmbH, 2019).

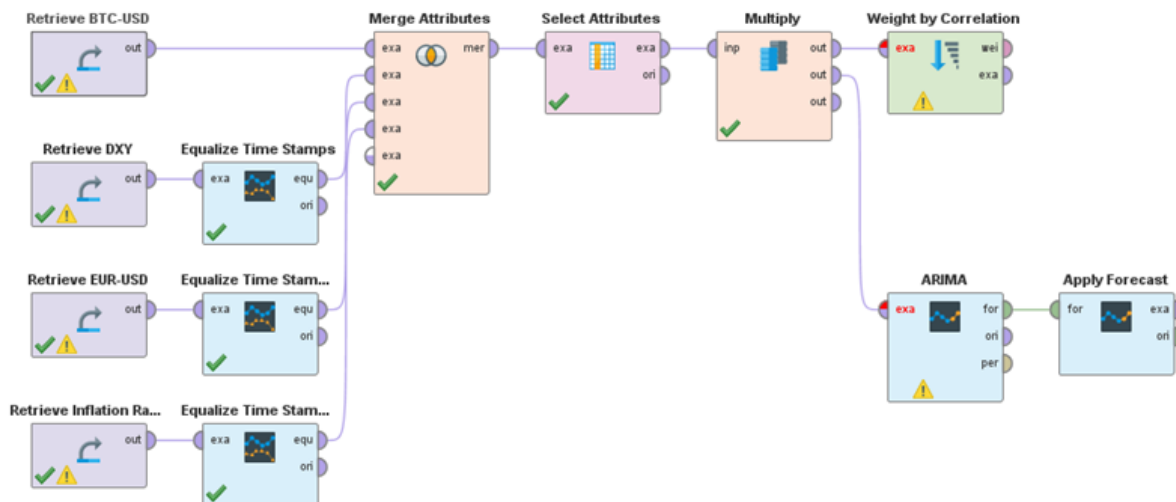

Figure 3. Modelling

3.2.4. *Evaluation*

Thre result from modeling, it was found that Inflation Rate is the attribute that has the most influence on BTC, followed by EUR-USD, and DXY with almost the same influence values (Figure 6). The data after modelling shown in Figure 7. In addition, the visualization of the forecasting results using the ARIMA algorithm shows that the value of BTC will continue to increase (Figure 8).

attribute	weight
DXY	0.185
EUR-USD	0.188
Core Inflation Rate	0.356

Figure 4. Weight

3.2.5. *Deployment*

The results of the ARIMA algorithm show that the model can be used by individuals or governments to understand that Inflation Rate US is one of the attributes that has the most influence on cryptocurrency price fluctuations, especially Bitcoin. It means when the inflation rate US rise, its affects to strengthen DXY (US Dollar Index), so other currency against dollar are going to decrease on value. When there are expectations of higher inflation, central banks may raise interest rates to combat inflation. Higher interest rates can make holding the U.S. dollar more attractive to investors, leading to increased demand for the currency, The U.S. dollar is often considered a safe-haven currency. In times of uncertainty or rising inflation, investors may flock to the U.S. dollar as a store of value, which can drive up its value, In the foreign exchange markets, currency values are relative. If the U.S. dollar is seen as a more attractive option compared to other currencies, its value can appreciate even in the face of rising inflation. In summary, while there is a general tendency for the U.S. Dollar Index to strengthen when inflation expectations rise, the relationship can be influenced by various other factors. It's essential to consider the broader economic and market context when analyzing how inflation may impact the value of the U.S. dollar. The influence values obtained can then be implemented into the ARIMA model to predict Bitcoin prices over a specified period of time.

Row No.	Date	forecast of ...	BTC	BTC and for...
1819	Oct 5, 2022 1...	?	20.161	20.161
1820	Oct 6, 2022 1...	?	19.955	19.955
1821	Oct 7, 2022 1...	?	19.547	19.547
1822	Oct 8, 2022 1...	?	19.417	19.417
1823	Oct 9, 2022 1...	?	19.446	19.446
1824	Oct 10, 2022 ...	?	19.141	19.141
1825	Oct 11, 2022 ...	?	19.051	19.051
1826	Oct 12, 2022 ...	?	19.157	19.157
1827	Oct 13, 2022 ...	?	18.728	18.728
1828	Oct 14, 2022 ...	18.749	?	18.749
1829	Oct 15, 2022 ...	18.758	?	18.758
1830	Oct 16, 2022 ...	18.768	?	18.768
1831	Oct 17, 2022 ...	18.777	?	18.777
1832	Oct 18, 2022 ...	18.787	?	18.787
1833	Oct 19, 2022 ...	18.796	?	18.796
1834	Oct 20, 2022 ...	18.806	?	18.806
1835	Oct 21, 2022 ...	18.815	?	18.815
1836	Oct 22, 2022 ...	18.824	?	18.824
1837	Oct 23, 2022 ...	18.834	?	18.834
1838	Oct 24, 2022 ...	18.843	?	18.843
1839	Oct 25, 2022 ...	18.853	?	18.853
1840	Oct 26, 2022 ...	18.862	?	18.862
1841	Oct 27, 2022 ...	18.871	?	18.871
1842	Oct 28, 2022 ...	18.880	?	18.880
1843	Oct 29, 2022 ...	18.890	?	18.890

ExampleSet (1,977 examples, 2 special attributes, 2 regular attributes)

Figure 5. Data after modelling

4. Results and Discussion

4.1. Advantages of Using and Trading Cryptocurrencies

Fluctuations in cryptocurrency trading tend to be high, but often attract the interest of investors worldwide. The rapid price fluctuations provide opportunities to make a large profit, but with high risk. The cryptocurrency market is available 24/7 due to its decentralized nature and not being physically traded in a specific location (Bartolucci et al., 2020). Furthermore, cryptocurrencies offer several advantages over traditional forms of payment and investment. Transactions made with cryptocurrencies are generally faster and more secure because they are recorded on a decentralized ledger known as blockchain. Unlike traditional banking systems, which can take several business days to clear transactions, cryptocurrency transactions are often completed within minutes. Moreover, transactions made with cryptocurrencies are also highly secure, as they are encrypted and cannot be easily altered or counterfeited. In addition, the decentralized nature of cryptocurrencies means that they are not subject to the same government regulations and restrictions as traditional forms of currency. This allows individuals and organizations to participate in global transactions without the need for intermediaries such as banks or financial institutions. Additionally, cryptocurrencies offer lower transaction fees compared to traditional banking and payment systems. Overall, the use and trading of cryptocurrencies offer several

advantages such as fast and secure transactions, anonymity, and lower transaction fees. However, it is important to note that investing in cryptocurrencies also comes with high risks and volatility, and investors should exercise caution and perform thorough research before investing. Transactions involving cryptocurrency can occur from various parts of the world. Purchasing goods and services using cryptocurrency is done online, so there is no need to worry about one's identity being publicly visible. This has arisen due to the increasing concern over identity and privacy theft of individuals and organizations. Peer-to-peer transactions are one of the biggest benefits of cryptocurrency, as they do not involve intermediaries in transactions.



Figure 6. Visualisasi data after modelling

4.2. Disadvantages of Using and Trading Cryptocurrencies

The issue of scalability arises when many countries still prohibit or do not recognize the validity of cryptocurrency as a legitimate global digital currency. Uneven technological development in different countries makes it difficult to implement a fully digital economy, such as cybersecurity risks, limited acceptance, environmental concern, and lack of understanding. The security of cryptocurrency requires the involvement of many countries in improving its security, which can surpass national banking security systems (Trump et al., 2018). Regulatory authorities worldwide face the nature and regulation of cryptocurrency, most of which are not clearly understood in terms of their system and risks. This leads to unequal cryptocurrency usage across different countries, as seen in India. “Cryptocurrency is nonsensical, unregulated, uncontrolled, and unmonitored” (Pavlou & Gefen, 2004).

The increase in cross-border transactions will open up new sectors in the economy. The acceleration of economic recovery post-pandemic will be realized faster. Small and medium-sized enterprises will be able to easily participate in the international digital market. Of course, global trade requires regulatory frameworks from governments to create a competitive and balanced market for creating products and innovation. It is also important to note that the digital economy requires flexibility in participating in the global market, so that there are no limitations in participating in it. (Nasir et al., 2019).

5. Conclusion

The emergence of cryptocurrency in the world can be used as a modern digital economic system if countries are ready to accept cryptocurrency as a legitimate virtual currency by creating regulations as limits and support from the government. The ease of national and international transactions, the opening up of new sectors in the form of international markets, and the acceleration of the development of a digital economy can all be created. However, all the opportunities that arise from the emergence of cryptocurrency cannot be fully utilized in the world, except for investors

who have started to learn about it from the beginning. The findings of the analysis using the Ishikawa Diagram identified key points from the cause and effect of cryptocurrency development. This was evaluated based on the available time-series data, and it was found that the development of cryptocurrency has a significant impact on the world, especially in countries that have a major influence, such as the USA. The analysis using ML also revealed the extent of the influence of US inflation on cryptocurrency value. In addition, the forecasting algorithm model that has been obtained can be used as a basis for the Indonesian government, especially the Central Bank, to observe the dominance of the USD in the world and the US inflation that can directly impact the value and strength of the Rupiah.

References

- Aggarwal, C. C. (2015). *Data Mining: The Textbook*. Springer International Publishing. <https://doi.org/10.1007/978-3-319-14142-8>
- Bartolucci, S., Destefanis, G., Ortu, M., Uras, N., Marchesi, M., & Tonelli, R. (2020). The Butterfly “Affect”: impact of development practices on cryptocurrency prices. *EPJ Data Science*, 9(1). <https://doi.org/10.1140/epjds/s13688-020-00239-6>
- Chapman, P., Clinton, J., Kerber, R., Khabaza, T., Reinartz, T., Shearer, C., & Rudiger, W. (2000). *Step-by-step Data Mining Guide*. DaimlerChrysler.
- Crosby, M., Nachiappan, Pattanayak, P., Verma, S., & Kalyanaraman, V. (2016). BlockChain Technology: Beyond Bitcoin. *Applied Innovation Review*, 2.
- Dietrich, D., Heller, R., & Yang, B. (2015). *Data science and Big Data Analytics: Discovering, Analyzing, Visualizing and Presenting Data*.
- Enajero, S. (2021). Cryptocurrency, Money Demand and the Mundell-Fleming Model of International Capital Mobility. *Atlantic Economic Journal*, 49(1), 57–69. <https://doi.org/10.1007/s11293-021-09701-w>
- Erdogan, S., Ahmed, M. Y., & Sarkodie, S. A. (2022). Analyzing asymmetric effects of cryptocurrency demand on environmental sustainability. *Environmental Science and Pollution Research*, 29(21), 31723–31733. <https://doi.org/10.1007/s11356-021-17998-y>
- Fang, F., Ventre, C., Basios, M., Kanthan, L., Martinez-Rego, D., Wu, F., & Li, L. (2022). Cryptocurrency trading: a comprehensive survey. In *Financial Innovation* (Vol. 8, Issue 1). Springer Science and Business Media Deutschland GmbH. <https://doi.org/10.1186/s40854-021-00321-6>
- Ftiti, Z., Louhichi, W., & Ben Ameer, H. (2021). Cryptocurrency volatility forecasting: What can we learn from the first wave of the COVID-19 outbreak? *Annals of Operations Research*. <https://doi.org/10.1007/s10479-021-04116-x>
- Han, J., Kamber, M., & Pei, J. (2012). *Data Mining: Concepts and Techniques* (Vol. 3).
- Hason Rudd, D., Huo, H., & Xu, G. (2022). Improved Churn Causal Analysis Through Restrained High-Dimensional Feature Space Effects in Financial Institutions. *Human-Centric Intelligent Systems*, 2(3–4), 70–80. <https://doi.org/10.1007/s44230-022-00006-y>
- ICE Futures U.S. (n.d.). *U.S. Dollar Index*.
- Ishikawa, K. (1989). *Introduction To Quality Control*.
- Johnson, M. (1999). *Core Inflation: A measure of inflation for policy purposes*.
- Karabağ, O., & Fadiloğlu, M. M. (2021). Augmented Winter’s method for forecasting under asynchronous seasonalities. *Journal of Management Analytics*, 8(1), 19–35. <https://doi.org/10.1080/23270012.2020.1839362>
- Kotu, V., & Deshpande, B. (2015). *Predictive Analytics and Data Mining: Concepts and Practice with RapidMiner*.
- Kullaya Swamy, A., & Sarojamma, B. (2020). Bank transaction data modeling by optimized hybrid machine learning merged with ARIMA. *Journal of Management Analytics*, 7(4), 624–648. <https://doi.org/10.1080/23270012.2020.1726217>
- Laursen, G. H. N., & Thorlund, J. (2017). *Business Analytics for Managers* (Vol. 2).

- Liu, J., & Serletis, A. (2019). Volatility in the Cryptocurrency Market. *Open Economies Review*, 30(4), 779–811. <https://doi.org/10.1007/s11079-019-09547-5>
- North, M. (2012). *Data Mining for the Masses*.
- Olson, D. L. (2007). Data mining in business services. *Service Business*, 1(3), 181–193. <https://doi.org/10.1007/s11628-006-0014-7>
- Pavlou, P. A., & Gefen, D. (2004). Building effective online marketplaces with institution-based trust. *Information Systems Research*, 15(1). <https://doi.org/10.1287/isre.1040.0015>
- Provost, F., & Fawcett, T. (2013). *Data Science for Business: What You Need to Know About Data Mining and Data-Analytic Thinking*.
- Russell, R. (2018). *Machine Learning: Step-by-Step Guide To Implement Machine Learning Algorithms with Python*.
- Sharda, R., Delen, D., & Turban, E. (2014). *Business intelligence and analytics: Systems for Decision Support* (Vol. 10).
- Telonis, G., & Groumpos, P. P. (2017). *A Critical Overview of Data Mining for Business Applications*. <https://knowledgecenter.ubt-uni.net/conferencehttps://knowledgecenter.ubt-uni.net/conference/2017/all-events/79>
- Wang, Q., Li, R., Wang, Q., & Chen, S. (2021). *Non-Fungible Token (NFT): Overview, Evaluation, Opportunities and Challenges*. <http://arxiv.org/abs/2105.07447>
- Ye, N. (2013). *Data Mining: Theories, Algorithms, and Examples*.
- Zhang, A. (2017). *Data Analytics: Practical Guide to Leveraging the Power of Algorithms, Data Science, Data Mining, Big Data, and Predictive Analysis to Improve Business, Work, and Life*.
- Zhao, L. (2021). The function and impact of cryptocurrency and data technology in the context of financial technology: introduction to the issue. In *Financial Innovation* (Vol. 7, Issue 1). Springer Science and Business Media Deutschland GmbH. <https://doi.org/10.1186/s40854-021-00301-w>